



***Society of Cable
Telecommunications
Engineers***

**ENGINEERING COMMITTEE
Interface Practices Subcommittee**

AMERICAN NATIONAL STANDARD

ANSI/SCTE 148 2016

Specifications for Male “F” Terminator, 75 ohm

NOTICE

The Society of Cable Telecommunications Engineers (SCTE) Standards and Recommended Practices (hereafter called documents) are intended to serve the public interest by providing specifications, test methods and procedures that promote uniformity of product, interchangeability, best practices and ultimately the long term reliability of broadband communications facilities. These documents shall not in any way preclude any member or non-member of SCTE from manufacturing or selling products not conforming to such documents, nor shall the existence of such standards preclude their voluntary use by those other than SCTE members, whether used domestically or internationally.

SCTE assumes no obligations or liability whatsoever to any party who may adopt the documents. Such adopting party assumes all risks associated with adoption of these documents, and accepts full responsibility for any damage and/or claims arising from the adoption of such Standards.

Attention is called to the possibility that implementation of this document may require the use of subject matter covered by patent rights. By publication of this document, no position is taken with respect to the existence or validity of any patent rights in connection therewith. SCTE shall not be responsible for identifying patents for which a license may be required or for conducting inquiries into the legal validity or scope of those patents that are brought to its attention.

Patent holders who believe that they hold patents which are essential to the implementation of this document have been requested to provide information about those patents and any related licensing terms and conditions. Any such declarations made before or after publication of this document are available on the SCTE web site at <http://www.scte.org>.

All Rights Reserved

© Society of Cable Telecommunications Engineers, Inc. 2016
140 Philips Road
Exton, PA 19341

Table of Contents

Title	Page Number
NOTICE	2
1. Scope	4
2. Normative References	4
3. Informative References	4
4. Compliance Notation	5
5. Definitions	5
5.1. Definitions	5
6. Electric Requirements	5
6.1. Bandwidth	5
6.2. Impedance	5
6.3. Return Loss	5
6.4. Shielding Effectiveness	6
7. Mechanical	6
7.1. Physical dimensions	6
7.2. Withstand Tightening Torque	6
8. Environmental Requirements	6
8.1. Interface Moisture Migration	6
8.2. Salt Spray	6

List of Figures

Title	Page Number
FIGURE 1: MALE 'F' TERMINATOR PHYSICAL REQUIREMENTS	7

1. Scope

The purpose of this specification is to specify requirements of the Male “F” Terminators that are used on “F” ports as specified in ANSI/SCTE 01 2015 and ANSI/SCTE 02 2015. This specification is not intended to limit or restrict any manufacturers from innovative designs and product improvements.

2. Normative References

The following documents contain provisions, which, through reference in this text, constitute provisions of the standard. At the time of Subcommittee approval, the editions indicated were valid. All standards are subject to revision; and while parties to any agreement based on this standard are encouraged to investigate the possibility of applying the most recent editions of the documents listed below, they are reminded that newer editions of those documents may not be compatible with the referenced version.

- ANSI/SCTE 01 2015, Specification for “F” Port, Female, Outdoor
- ANSI/SCTE 02 2015, Specification for “F” Port, Female, Indoor
- ANSI/SCTE 48-1 2015, Test Method for Measuring Shielding Effectiveness of Passive and Active Devices Using a GTEM Cell
- ANSI/SCTE 60 2010, Test Method for Interface Moisture Migration Double Ended
- ANSI/SCTE 98 2014, Test Method for Withstand Tightening Torque - 'F' Male
- ANSI/SCTE 143 2013, Test Method for Salt Spray
- ANSI/SCTE 144 2012, Test Procedure for Measuring Transmission and Reflection

3. Informative References

The following documents may provide valuable information to the reader but are not required when complying with this standard.

- No references are available

4. Compliance Notation

<i>shall</i>	This word or the adjective “ <i>required</i> ” means that the item is an absolute requirement of this specification.
<i>shall not</i>	This phrase means that the item is an absolute prohibition of this specification.
<i>forbidden</i>	This word means the value specified shall never be used.
<i>should</i>	This word or the adjective “ <i>recommended</i> ” means that there may exist valid reasons in particular circumstances to ignore this item, but the full implications should be understood and the case carefully weighted before choosing a different course.
<i>should not</i>	This phrase means that there may exist valid reasons in particular circumstances when the listed behavior is acceptable or even useful, but the full implications should be understood and the case carefully weighed before implementing any behavior described with this label.
<i>may</i>	This word or the adjective “ <i>optional</i> ” means that this item is truly optional. One vendor may choose to include the item because a particular marketplace requires it or because it enhances the product, for example; another vendor may omit the same item.
<i>deprecated</i>	Use is permissible for legacy purposes only. Deprecated features may be removed from future versions of the standard. Implementations should avoid use of deprecated features.

5. Definitions

5.1. Definitions

Dielectric	The material that is used to insulate the center conductor from contacting the outer housing.
Thread Relief	A reduced diameter section of the threaded surface to allow the tool to run out. This feature is optional.
Center Conductor	The inner conductor of a coaxial cable or pin of a male “F” connector.
Reference Plane	The reference plane on the male “F” connector is the mating surface that seats against the female “F” port. It is also the plane from where all horizontal dimensions are taken.

6. Electric Requirements

6.1. Bandwidth

Shall be a minimum of 5 MHz to 1,002 MHz, unless otherwise specified.

6.2. Impedance

Shall be 75 ohms nominal.

6.3. Return Loss

Shall be ≥ 25 dB, when tested in accordance to ANSI/SCTE 144 2012, Test Procedure for Measuring Transmission and Reflection.

6.4. Shielding Effectiveness

Shall be a minimum of 100 dB, when tested in accordance with ANSI/SCTE 48-1 2015, Test Method for Measuring Shielding Effectiveness of Passive and Active Devices Using a GTEM Cell.

7. Mechanical

7.1. Physical dimensions

The recommended physical dimensions for the male “F” terminator *shall* be as specified in Figure 1, Table 1.

7.2. Withstand Tightening Torque

Shall withstand a minimum tightening torque of 40 lbs-in. without damage when measured per ANSI/SCTE 98 2014, Test Method for Withstand Tightening Torque – ‘F’ Male.

8. Environmental Requirements

8.1. Interface Moisture Migration

No moisture *shall* migrate into the connector interface when tested according to ANSI/SCTE 60 2010, Test Method for Interface Moisture Migration Double Ended.

8.2. Salt Spray

Shall be exposed to 1000 hours min. continuous salt spray with no degradation in electrical or mechanical performance when tested per ANSI/SCTE 143 2013, Test Method for Salt Spray.

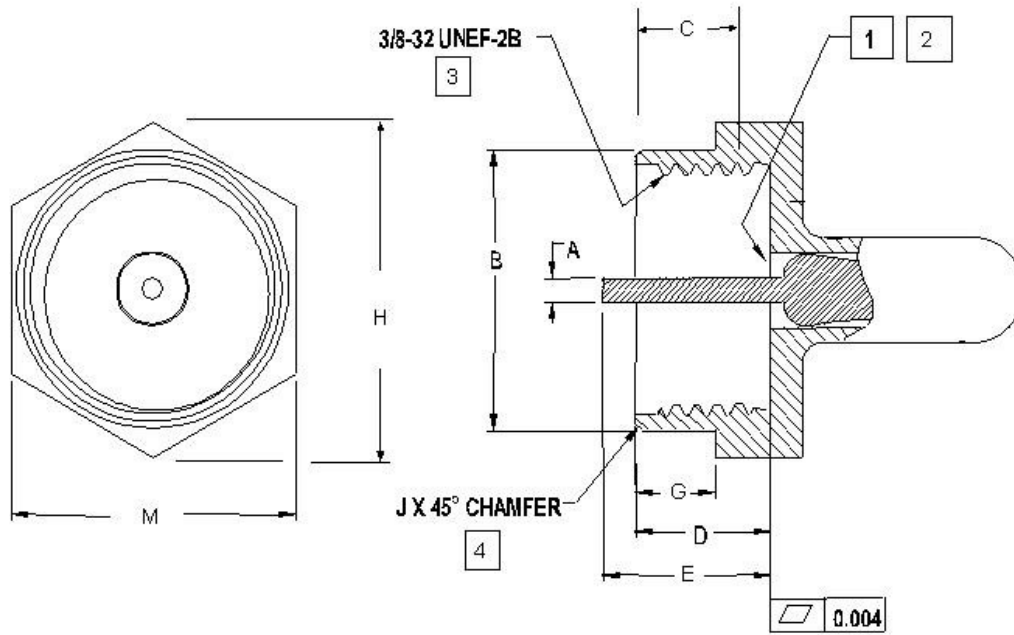

Figure 1: Male 'F' Terminator Physical Requirements

DESCRIPTION	DIM	mm		Inches		Notes
	Ref.	min.	max.	min.	max.	
Center Conductor Diameter	A	0.76	1.066	0.030	0.042	
Sealing Sleeve Diameter	B	10.41	11.05	0.410	0.435	
Nut Threaded Length	C	3.97	-	0.156	-	3
Reference Plane Depth to Nut Leading Edge	D	4.29	6.10	0.169	0.240	
Center Conductor to Reference Plane Length	E	6.35	9.53	0.250	0.375	
Nut to Sealing Sleeve Interface Length	G	1.78	4.45	0.070	0.175	
Maximum Envelope Dimension	H	-	12.95	-	0.510	
Chamfer Break	J	0.25	0.73	0.010	0.030	4
Nut Dimension Flat-Flat	M	10.97	11.14	0.432	0.438	

Notes:

1. No Material protrusion allowed beyond reference plane.
2. The Mating of the Female "F" to the Reference Plane *should* not be impeded
3. Minimum One Thread Lead In
4. Radius Optional
5. Drawing not to scale