



***Society of Cable  
Telecommunications  
Engineers***

---

**ENGINEERING COMMITTEE  
Interface Practices Subcommittee**

---

**AMERICAN NATIONAL STANDARD**

**ANSI/SCTE 91 2015**

**Specification for 5/8-24  
RF & AC Equipment Port, Female**

## NOTICE

The Society of Cable Telecommunications Engineers (SCTE) Standards and Recommended Practices (hereafter called documents) are intended to serve the public interest by providing specifications, test methods and procedures that promote uniformity of product, interchangeability, best practices and ultimately the long term reliability of broadband communications facilities. These documents shall not in any way preclude any member or non-member of SCTE from manufacturing or selling products not conforming to such documents, nor shall the existence of such standards preclude their voluntary use by those other than SCTE members, whether used domestically or internationally.

SCTE assumes no obligations or liability whatsoever to any party who may adopt the documents. Such adopting party assumes all risks associated with adoption of these documents, and accepts full responsibility for any damage and/or claims arising from the adoption of such Standards.

Attention is called to the possibility that implementation of this document may require the use of subject matter covered by patent rights. By publication of this document, no position is taken with respect to the existence or validity of any patent rights in connection therewith. SCTE shall not be responsible for identifying patents for which a license may be required or for conducting inquiries into the legal validity or scope of those patents that are brought to its attention.

Patent holders who believe that they hold patents which are essential to the implementation of this document have been requested to provide information about those patents and any related licensing terms and conditions. Any such declarations made before or after publication of this document are available on the SCTE web site at <http://www.scte.org>.

All Rights Reserved

© Society of Cable Telecommunications Engineers, Inc. 2015  
140 Philips Road  
Exton, PA 19341

## TABLE OF CONTENTS

1.0	SCOPE .....	1
2.0	COMPLIANCE NOTATION .....	1
3.0	GENERAL REQUIREMENTS .....	2
4.0	DEFINITIONS.....	2
5.0	PHYSICAL DIMENSIONS .....	2

## *LIST OF FIGURES*

FIGURE 1 – PHYSICAL DIMENSIONS FOR 5/8-24 RF & AC EQUIPMENT PORT,  
FEMALE

3

## 1.0 SCOPE

The purpose of this specification is to serve as a recommended guideline for the physical dimensions of all female 5/8 – 24 equipment ports for RF and AC powering that are used in the 75 ohm RF broadband communications industry. It is not the purpose of this standard to specify the details of manufacturing.

## 2.0 INFORMATIVE REFERENCES

The following documents may provide valuable information to the reader but are not required when complying with this standard.

### 2.1 SCTE References

ANSI/SCTE 92 2012 - Specification for 5/8-24 Plug (Male), Trunk & Distribution Connectors

### 2.2 Standards from other Organizations

ASME Y14.5M-1994 - Dimensioning and Tolerancing

## 3.0 COMPLIANCE NOTATION

“SHALL”	This word or the adjective “REQUIRED” means that the item is an absolute requirement of this specification.
“SHALL NOT”	This phrase means that the item is an absolute prohibition of this specification.
“SHOULD”	This word or the adjective “RECOMMENDED” means that there may exist valid reasons in particular circumstances to ignore this item, but the full implications should be understood and the case carefully weighted before choosing a different course.
“SHOULD NOT”	This phrase means that there may exist valid reasons in particular circumstances when the listed behavior is acceptable or even useful, but the full implications should be understood and the case carefully weighed before implementing any behavior described with this label.
“MAY”	This word or the adjective “OPTIONAL” means that this item is truly optional. One vendor may choose to include the item because a particular marketplace requires it or because it enhances the product, for example; another vendor may omit the same item.

#### **4.0 GENERAL REQUIREMENTS**

Samples of the finished products shall be inspected to ensure that they conform to the physical dimensions specified in this document.

#### **5.0 DEFINITIONS**

- 5.1 Reference Plane: The reference plane on the female 5/8-24 equipment port is the mating surface that seats with the male 5/8-24 port.
- 5.2 Parting Line (relevant to casting process only): A raised mark left on the surface of a part as a result of the gap between two halves of a die.

#### **6.0 PHYSICAL DIMENSIONS**

The recommended physical dimensions for 5/8-24 female equipment ports shall be as specified in Figure 1.

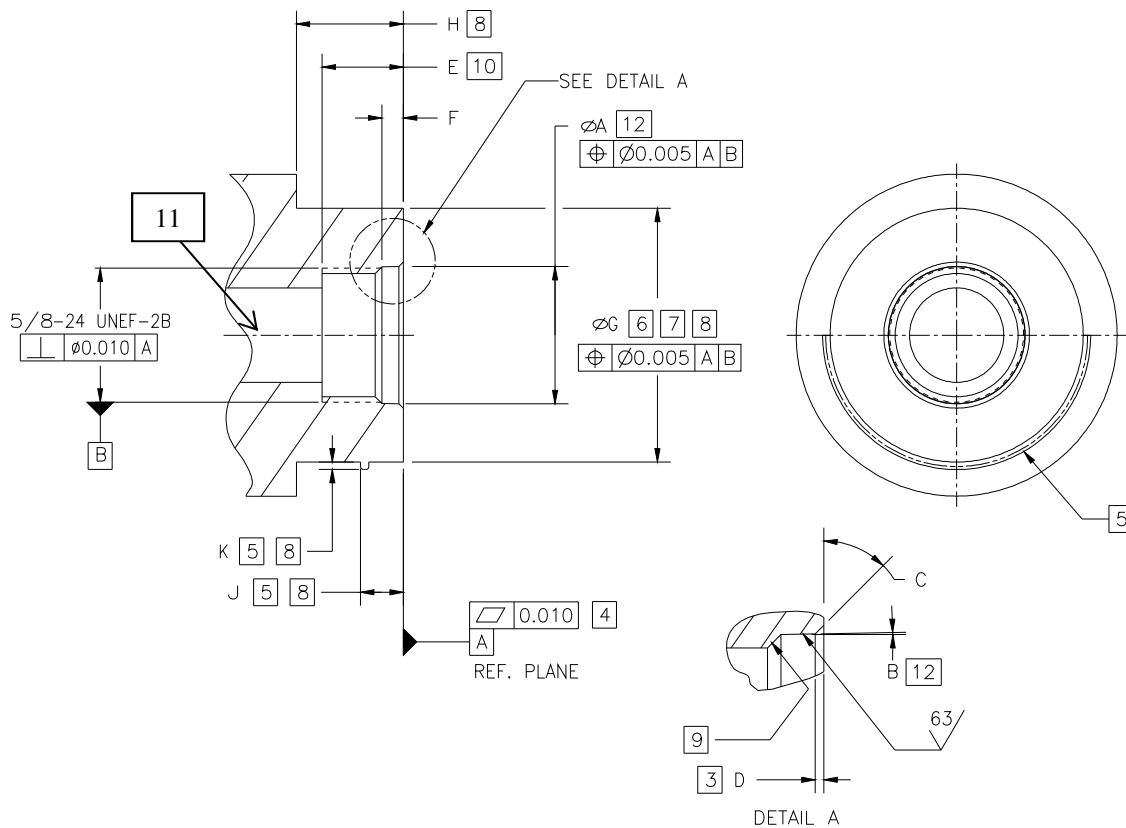

**Figure 1 – Physical Dimensions of 5/8-24 RF & AC Equipment Port - Female**

DESCRIPTION	DIM	mm		inches		NOTES
		MIN	MAX	MIN	MAX	
O-Ring Gland Internal Diameter	A	16.21	16.38	0.638	0.645	12
O-Ring Gland Angle	B	-	3°	-	3°	12
Chamfer Angle	C	40°	50°	40°	50°	
Chamfer Length	D	0.25	0.64	0.010	0.025	3
Full Thread Depth	E	9.65	-	0.380	-	10
O-Ring Gland Depth	F	2.29	2.79	0.090	0.110	
Port External Diameter	G	18.80	41.28	0.740	1.625	6, 7, 8
Port Length	H	12.70	-	0.500	-	8
Shrink Sleeve Ridge Distance From Port End	J		9.53		0.375	5, 8
Shrink Sleeve Ridge Height	K	0.89		0.035		5, 8

NOTES:

- 1 – Drawing not to scale
- 2 – Interpret drawing in accordance with ASME Y14.5M-1994
- 3 – Radius optional
- 4 – After finish applied, this surface to be kept free of paint
- 5 – Shrink sleeve retaining ridge or equivalent feature shall be continuous for 180 degrees min of port perimeter. Alternatively, shrink sleeving may be retained by the radiused corners of a hex incorporated into the open end of the port. Shrink sleeve ridge and/or hex corners shall be a min height and width of 0.035 in (0.89 mm), located no further than 0.375 in (9.53 mm) from ref. plane. Geometry optional. All exterior corners 0.015R in (0.38R mm) minimum.
- 6 – If cast feature, allowable flash height along parting line (of equipment ports only) to be 0.01 in (0.25 mm) max.
- 7 – External port geometry optional
- 8 – Dimension applies to equipment ports only
- 9 – Reference only: Typical machining practice dictates a 0.030 in (0.76 mm) max chamfer (45°).
- 10 – Typical machining practices dictates 0.083 in (2.11 mm) max bottoming tap clearance. Tap clearance should be provided in addition to the thread depth E
- 11 – The 5/8-24 female port and equipment attached to it must accept the male 5/8-24 connector with the pin lengths (D1 and D2) as specified in SCTE 92.
- 12 – The O-ring clang internal diameter, dimension A, starts at the reference plane, datum A, with draft (O-ring clang angle, dimension B) to be taken inward (subtracted).